



KIESELMANN
FLUID PROCESS GROUP

Operating instructions

- Translation of the original -

Vacuum valve

Type: 6160

DN 50 - DN 150
spring loaded



English **GBR**



20.04.2016

KIESELMANN GmbH

Paul-Kieselmann-Str.4-10
D - 75438 Knittlingen

☎ +49 (0) 7043 371-0 ♦ Fax: +49 (0) 7043 371-125
www.kieselmann.de ♦ sales@kieselmann.de

List of contents

1.	General Information.....	2
1.1	Information for your safety	2
1.2	Marking of security instructions in the operating manual	2
1.3	Designated use	2
1.4	Personnel	2
1.5	Modifications, spare parts, accessories	2
1.6	General instructions	2
2.	Safety informations.....	3
2.1	Intended use	3
2.2	General safety instructions	3
2.3	General notes	3
3.	Function and operation.....	4
3.1	Description of function	4
3.2	Installation instructions.....	4
3.3	Welding guidelines	4
3.4	Service and maintenance	4
3.5	Technical Data	5
3.6	Identification	5
3.7	Pressure setting	6
4.	Disassembly / Assembly	7
4.1	DN 50 - DN 100	7
4.2	DN 125 - DN 150	8
5.	Drawing and dimensions	9
6.	Spare parts list	11
7.	Performance chart.....	12



1. General Information

1.1 Information for your safety

We are pleased that you have decided for a high-class KIESELMANN product. With correct application and adequate maintenance, our products provide long time and reliable operation.





Before installation and initiation, please carefully read this instruction manual and the security advices contained in it. This guarantees reliable and safe operation of this product and your plant respectively. Please note that an incorrect application of the process components may lead to great material damages and personal injury.

In case of damages caused by non observance of this instruction manual, incorrect initiation, handling or external interference, guarantee and warranty will lapse!

Our products are produced, mounted and tested with high diligence. However, if there is still a reason for complaint, we will naturally try to give you entire satisfaction within the scope of our warranty. We will be at your disposal also after expiration of the warranty. In addition, you will also find all necessary instructions and spare part data for maintenance in this instruction manual. If you don't want to carry out the maintenance by yourself, our KIESELMANN service team will naturally be at your disposal.

1.2 Marking of security instructions in the operating manual

Hints are available in the chapter "safety instructions" or directly before the respective operation instruction. The hints are highlighted with a danger symbol and a signal word. Texts beside these symbols have to be read and adhered to by all means. Please continue with the text and with the handling at the valve only afterwards.

Symbol	Signal word	Meaning
	DANGER	Imminent danger which <u>will result</u> severe personal injury or death.
	WARNING	Imminent danger which <u>may result</u> severe personal injury or death.
	CAUTION	Dangerous situation which may cause slight personal injury or material damages.
	ATTENTION	An harmful situation which may result in damages of the product itself or of adjacent vicinity.
	NOTICE	Marks application hints and other information which is particularly useful.

1.3 Designated use

The fitting is designed exclusively for the purposes described below. Using the fitting for purposes other than those mentioned is considered contrary to its designated use. KIESELMANN cannot be held liable for any damage resulting from such use. The risk of such misuse lies entirely with the user. The prerequisite for the reliable and safe operation of the fitting is proper transportation and storage as well as competent installation and assembly.

Operating the fitting within the limits of its designated use also involves observing the operating, inspection and maintenance instructions.

1.4 Personnel

Personnel entrusted with the operation and maintenance of the tank safety system must have the suitable qualification to carry out their tasks. They must be informed about possible dangers and must understand and observe the safety instructions given in the relevant manual. Only allow qualified personnel to make electrical connections.

1.5 Modifications, spare parts, accessories

Unauthorized modifications, additions or conversions which affect the safety of the fitting are not permitted. Safety devices must not be bypassed, removed or made inactive. Only use original spare parts and accessories recommended by the manufacturer.

1.6 General instructions

The user is obliged to operate the fitting only when it is in good working order. In addition to the instructions given in the operating manual, please observe the relevant accident prevention regulations, generally accepted safety regulations, regulations effective in the country of installation, working and safety instructions effective in the user's plant.

2. Safety informations

2.1 Intended use

This vacuum valve is used to prevent underpressures in tanks and vessels for food and beverage industry, pharmaceutical and chemical industries as well as in biotechnology.

2.2 General safety instructions



ATTENTION

- To avoid danger and damage, the fitting must be used in accordance with the safety instructions and technical data contained in the operating instructions.



WARNING

- Dismantling the valve or valve assemblies from the plant can cause injuries from fluids or gases flowing out. Dismantle the valve or valve assembly only when the plant has been rendered pressure-less and free of liquid and gas.
- Referring to the used sealing materials the vacuum valves are suitable for a minimum operating temperature at -10 °C. An operation at low process or ambient temperatures may affect the safety function. Therefore, appropriate measures shall be taken for an operation at temperatures below +5 °C.



CAUTION

- If the set pressure is raised (by turns of the nuts (11) clockwise), results in changes in the opening characteristics. This can result in damage to the tanks.
- Internal or external dirt may impair the function of the fitting or the safety equipment. Therefore the fitting must be operated in a way that protects it from external influences and it must be cleaned and maintained at regular intervals.
- Remove transport insurance before initial operation.
- Follow the instructions of the welding guidelines.

2.3 General notes



NOTICE

- All data are in line with the current state of development. Subject to change as a result of technical progress.

3. Function and operation

3.1 Description of function

The function of the vacuum valve is to prevent inadmissible pressure shortfalls (≤ 1 bar absolute pressure), in tanks and containers, which can result in damage. At underpressure, the valve opens to the atmosphere. The pressure in the tank is brought to the atmospheric pressure by the inflowing air. When the pressures become equal, the valve closes by spring force. The flow capacities referred to the relevant underpressure are shown in the capacity diagram (see "7. Performance chart" on page 12).

3.2 Installation instructions

Fitting position

The vacuum valve is generally to be installed vertically (see figure on the right).



ATTENTION

- Impurities can cause damage to the sealing surfaces and the seals. Clean inside areas prior to assembly.



3.3 Welding guidelines

Sealing elements integrated in weld components must generally be removed prior to welding. To prevent damage, welding should be undertaken by certified personnel (EN287). Use the TIG (tungsten inert gas) welding process.

3.4 Service and maintenance

► Service

Die Wartungsintervalle sind von den Betriebsbedingungen "Temperatur, Temperaturintervalle, Reinigungsmedium, Medium, Druck und Schalthäufigkeit" abhängig. Es wird empfohlen die Dichtungen präventiv im 2-jährigen Zyklus zu wechseln, wobei nach Zustand der Dichtung längere Wartungsintervalle vom Anwender festzulegen sind.



NOTICE

EPDM; Viton; k-flex; NBR; HNBR ⇒
Silicone ⇒
Thread ⇒

Lubricant recommendation

Klüber Paraliq GTE703*
Klüber Sintheso pro AA2*
Interflon Food Grease*

*) It is only permitted to use approved lubricants, if the respective fitting is used for the production of food or drink. Please observe the relevant safety data sheets of the manufacturers of lubricants.

► Cleaning

A complete cleaning of all the parts that have come in contact with the product is only possible in the dismantled state.

The cleaning of the fitting surfaces that touch the product takes place with the tank cleaning. The cleaning of the external surfaces must be performed at regular intervals. The cleaning cycles are to be defined by the user.

3.5 Technical Data

Model:	Aeration valve, weight loaded	
Valve size:	DN 50 - DN 150	
Connections:	- Flange - Welding flange DIN EN10357	
Temperature range:	-10° to +95°C medium dependent (see "2 . 2 General safety instructions" on page 3)	
Operation pressure:	DN 50	= 8 bar
	DN 65 - DN 80	= 10 bar
	DN 100 - DN 150	= 16 bar
Set pressure:	3 mbar (30mmWS) (factory setting)	
min. design pressure:	5 mbar (50mmWS)	
in product contact Material:	Stainless steel:	<ul style="list-style-type: none"> • 1.4301 / AISI304 • 1.4404 / AISI316L
	Surfaces:	• Ra < 0,8µm e-polished
	Seal material:	• EPDM

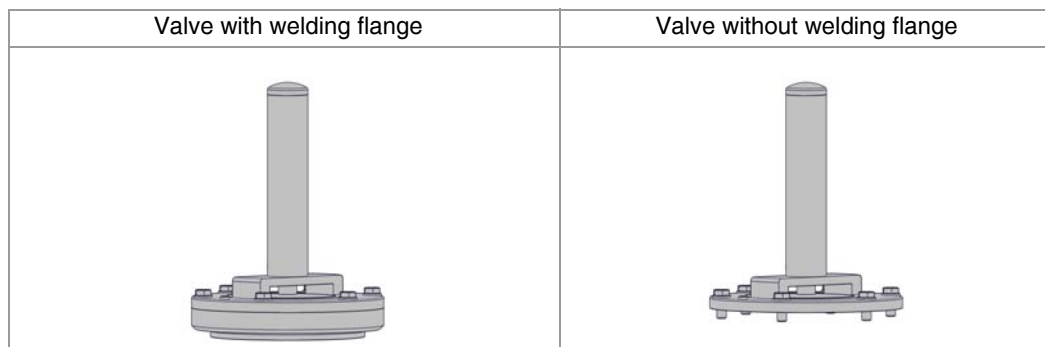

3.6 Identification

- A = Designation
- B = Notified body
- C = Manufacturer
- D = Nominal diameter
- E = max. allowable pressure
- F = min. / max. allowable Temperature
- G = Material
- H = Order number
- I = Set pressure in mbar
- J = Set pressure in mm WC (Water column)
- K = Date of manufacture

K1= lasered
K2= label

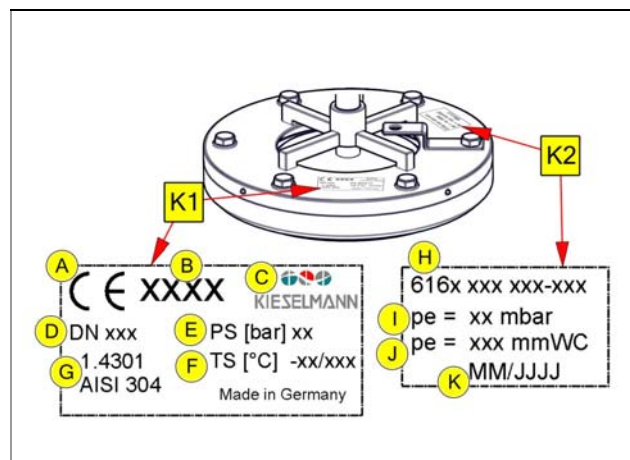

3.7 Pressure setting

The vacuum valve is set at the factory to an underpressure of 3 mbar (30mm WC). At this underpressure, the valve opens to the atmosphere.



ATTENTION

- If the set pressure P_0 is raised (by turns of the nuts (11) clockwise), results in changes in the opening characteristics. This can result in damage to the tanks.

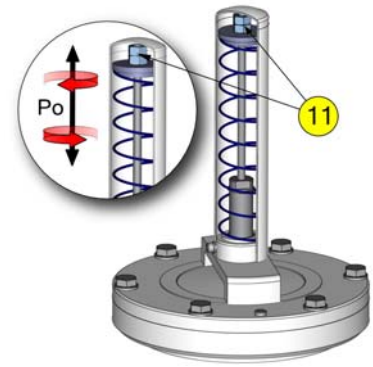

NOTICE

- If the set pressure P_0 is decreased [by turns of the nuts (11) anticlockwise], the closing function is not guaranteed any more.
If the set pressure is raised (by turns of the nuts (16) clockwise), then the water column (WC) increase on the maximum water column WC_{max} .

DN	50	65	80	100	125	150
$WC_{min.}$ (mm)	30	30	30	30	30	30
$WC_{max.}$ (mm)	150	150	150	150	150	150

4. Disassembly / Assembly

4.1 DN 50 - DN 100

➤ Disassembly O-rings (D1), (D2)

- Unscrew the hexagon screws (14) and remove the complete valve.
- Remove the O-Ring (D1) from the groove.
- Remove the cover (7) from housing flange (1).
- Unscrew nuts (11) and remove distance (10) and spring (9).
- Unscrew nut (11) and remove disc (6).
- Remove the complete valve plate from the housing flange (1) and clamp it at the outer diameter of plate (2) in the vise (with soft jaws).
- Unscrew the bolt (5) with a pin wrench (M1).
- Remove the O-ring (D2) from the groove.
- Thoroughly clean of grease the thread in the bolt (5) and plate (2).

➤ Assembly

- Thoroughly clean and slightly lubricate mounting areas and running surfaces. (see "3. 4 Service and maintenance" on page 4).
- Assemble in reverse order.



NOTICE

- Secure the threaded joint of the plate (2) and bolt (5) with a removable screw locking device

- Test proper performance in the operating state according to the specified performance data.

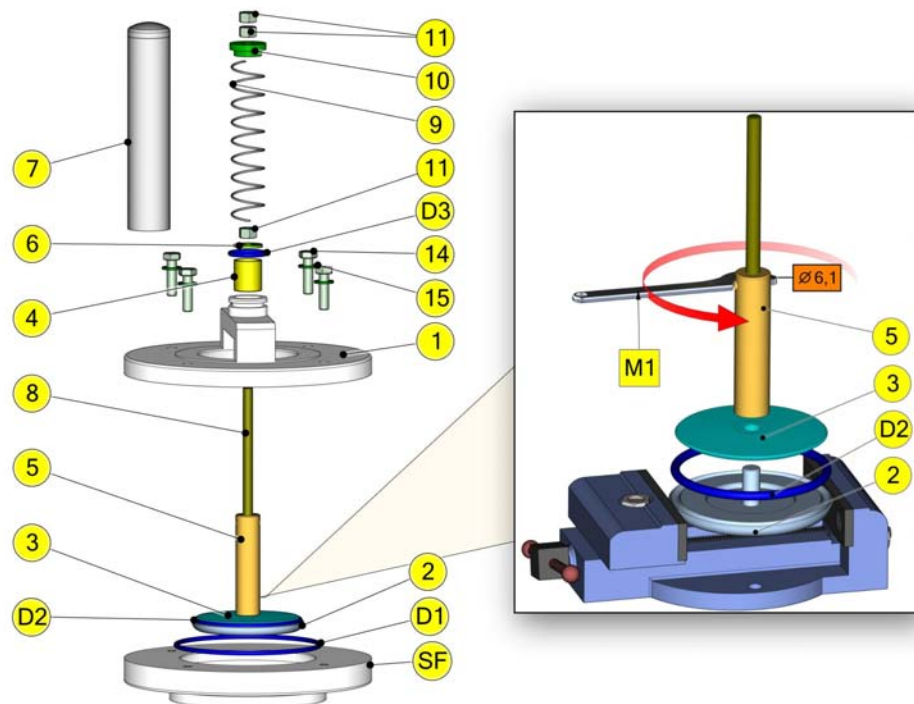

Fig. 1

4.2 DN 125 - DN 150

► Disassembly O-rings (D1), (D2)

- Unscrew the hexagon screws (14) and remove the complete valve.
- Remove the O-Ring (D1) from the groove.
- Loosen screw (13).
- Turn the cover (7) clockwise 15° and pull it from housing flange (1).
- Unscrew nuts (11) and remove distance (10) and spring (9).
- Develop the circlip (6) with a circlip pliers.
- Remove the complete valve plate from the housing flange (1) and clamp it at the outer diameter of plate (2) in the vise (with soft jaws).
- Unscrew the bolt (5) with a socket spanner (M1)[SW19].
- Remove the O-ring (D2) from the groove.
- Thoroughly clean of grease the thread in the bolt (5) and plate (2).

► Assembly

- Thoroughly clean and slightly lubricate mounting areas and running surfaces. (see "3. 4 Service and maintenance" on page 4).
- Assemble in reverse order.



NOTICE

- Secure the threaded joint of the plate (2) and bolt (5) with a removable screw locking device

- Test proper performance in the operating state according to the specified performance data.

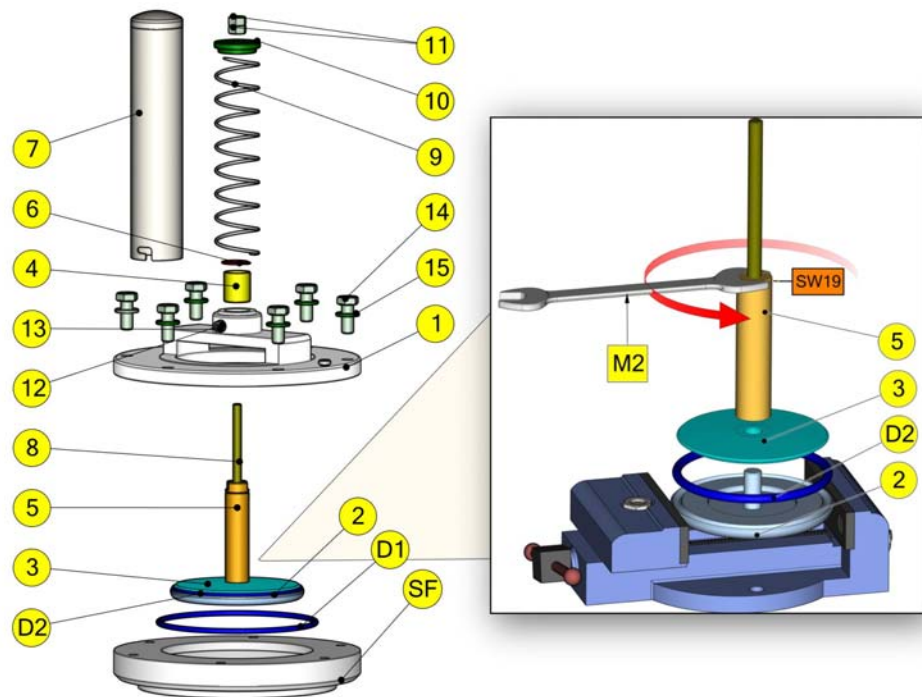

Fig. 2

5. Drawing and dimensions

DN50 - DN 100

- 1) = Housing flange
- 2) = Piston lower
- 3) = Piston upper
- 4) = Plain bearing
- 5) = Bolt
- 6) = Disc
- 7) = a) Hood without Sensor mounting
b) Hood with Sensor mounting
- 8) = Threaded rod
- 9) = Spring
- 10) = Spring plate
- 11) = Hexagon nut
- 12) = -
- 13) = -
- 14) = Hexagon screw
- 15) = Disc

- D1 = O-ring
- D2 = O-ring
- D3 = O-ring
- Cap= Cap
- SF = Welding flange
- G1)= Threaded joint secure with removeable screw retention

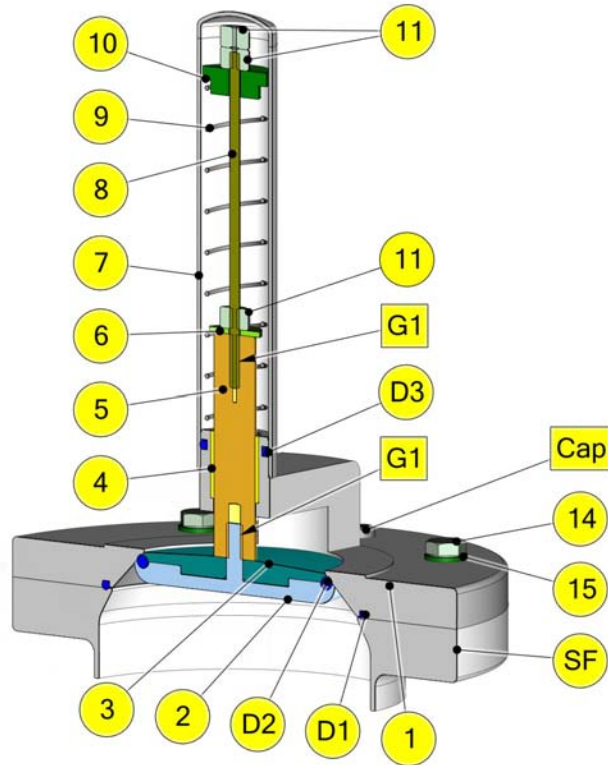

DN125 - DN 150

- 1) = Housing flange
- 2) = Piston lower
- 3) = Piston upper
- 4) = Plain bearing
- 5) = Threaded rod
- 6) = Circlip
- 7) = a) Hood without Sensor mounting
b) Hood with Sensor mounting
- 8) = Bolt
- 9) = Spring
- 10) = Spring plate
- 11) = Hexagon nut
- 12) = Disc
- 13) = Hexagon screw
- 14) = Hexagon screw
- 15) = Disc

- D1 = O-ring
- D2 = O-ring
- Cap= Cap
- SF = Welding flange
- G1)= Threaded joint secure with removeable screw retention

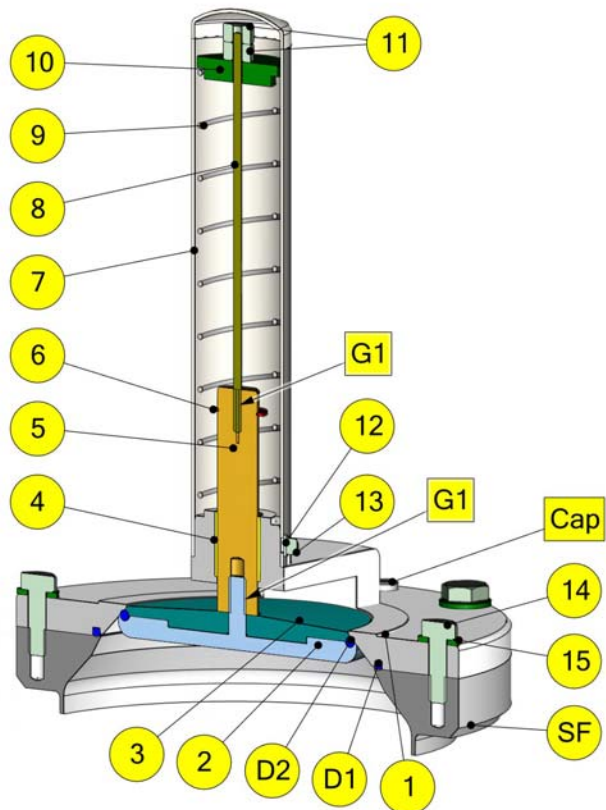
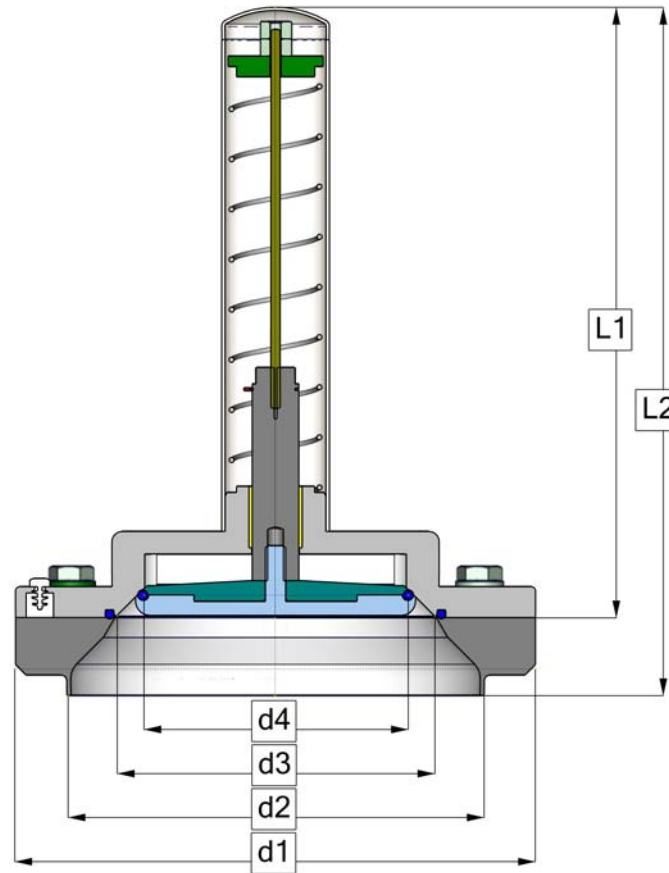

Fig. 3



	DN50 mm	DN65 mm	DN80 mm	DN100 mm	DN125 mm	DN150 mm
L1	182	187	220	213	298	298
L2	210	216	253,5	243	336	337
d1	129	154	204	204	254	304
d2	85x2	104x2	129x2	154x2	204x2	254x2
d3	74	67,6	112	131	155	180
d4	55	90,4	83,6	104	128	152
Weight	1,6 kg	2,5 kg	4,6 kg	4,5 kg	8,1 kg	10,8 kg

Tab.1

6. Spare parts list

		DN 50	DN 65	DN 80	DN 100	DN 125	DN 150	
1	Housing flange	6161 050 010-022	6161 065 010-022	6161 080 010-022	6161 100 010-022	6160 125 010-022	6160 150 002-022	
2	Piston lower	6161 050 018-021	6161 065 018-021	6161 080 018-021	6161 100 018-021	6161 125 018-021	6161 150 018-021	
3	Piston upper	6161 050 019-021	6161 065 019-021	6161 080 019-021	6161 100 019-021	6161 125 019-021	6161 150 019-021	
4	Plain bearing	8050 015 025-060	8050 023 020-060			8050 027 024-060		
5	Bolt	6160 050 020-021	6160 080 020-021			6138 125 662-220		
6	Circlip DIN471	-	-	-	-	8084 024 120-031		
7a	Hood without SH ¹	6160 065 004-022		6160 100 004-022		6138 125 664-022		
7b	Hood with SH	-		-		-		
8	Threaded rod	8112 006 110-020	8112 008 105-020	8112 008 125-020		8112 008 185-020		
9	Spring	8150 207 223-031		8150 207 224-031		8150 263 119-031		
10	Distance disc POM	6160 050 005-057	6160 100 005-057			6138 125 663-057		
11	Nut DIN934	8107 010 000-020 (3x)				8107 010 000-020 (2x)		
12	Disc DIN125	-				8071 064 001-020		
13	Screw DIN912	-				8095 006 010-020		
14	Screw DIN933	8106 006 025-020 (4x)		8106 008 030-020 (4x)	8106 008 030-020 (6x)	8106 012 030-020 (6x)	8106 012 035-020 (6x)	
15	Disc DIN125	8071 064 001-020 (4x)		8071 084 001-020 (4x)	8071 084 001-020 (6x)	8071 130 001-020 (6x)		
D1	O-ring	2304 050 050-054	2304 065 050-054	2304 080 050-054	2304 100 050-054	2304 125 050-054	2304 150 050-054	
D2	O-ring	2304 080 040-170	2304 090 035-170	2304 113 035-170	2304 130 045-170	2304 153 045-170	2304 180 050-170	
D3	O-ring	2304 025 035-055				-	-	
Cap	Cap PE	8010 000 002-060						
SF	Flange	6161 050 001-020	6161 065 001-020	6161 080 001-020	6161 100 001-020	6161 125 001-020	6161 150 001-020	
HP	Heating cartridge	8615 481 001-000 (2x)					8615 481 001-000 (4x)	

1. SH = Sensor mounting

Code Material Exterior Surfaces: xxxx xxx xxx-020 - 1.4301 - bright turned
 xxxx xxx xxx-021 - 1.4301 - E-polished
 xxxx xxx xxx-022 - 1.4301 - unpolished, glass-bead blasted

7. Performance chart

DN

Δp mbar	50	65	80	100	125	150
	m ³ /h	m ³ /h	m ³ /h	m ³ /h	m ³ /h	m ³ /h
0	-	-	-	-	-	-
5	34	14	25	45	58	74
10	73	83	135	233	333	569
15	105	147	253	424	579	1.087
20	136	201	365	601	804	1.585
25	163	266	467	756	1.000	2.039
30	194	319	559	899	1.186	2.249
35	221	371	644	1.032	1.337	2.437
40	245	406	718	1.147	1.446	2.618
45	268	439	790	1.223	1.543	2.786
50	289	479	839	1.293	1.632	2.951
55	309	507	883	1.361	1.718	3.111
60	328	537	925	1.426	1.796	3.259

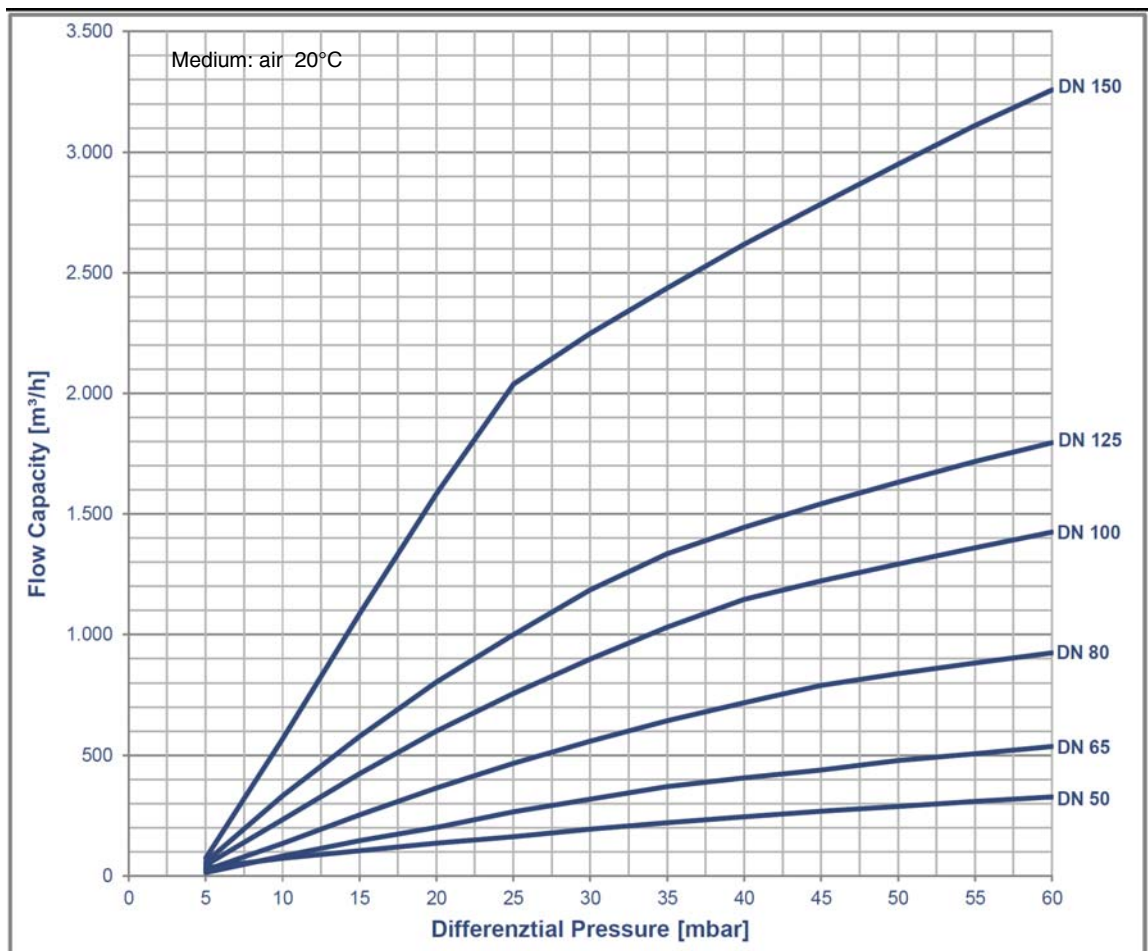

Diagram 1